

Mechanism of Aldolase

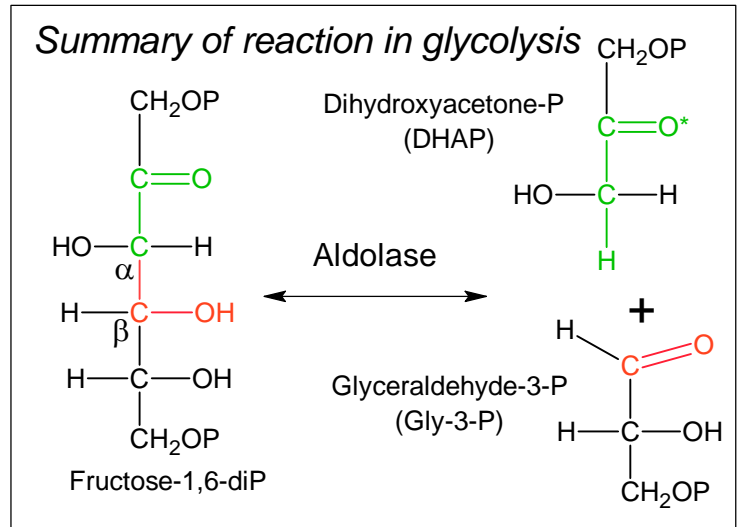

Mechanism

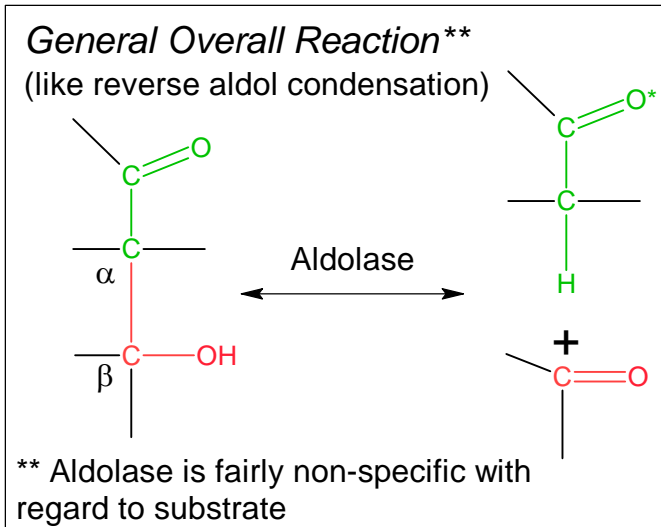
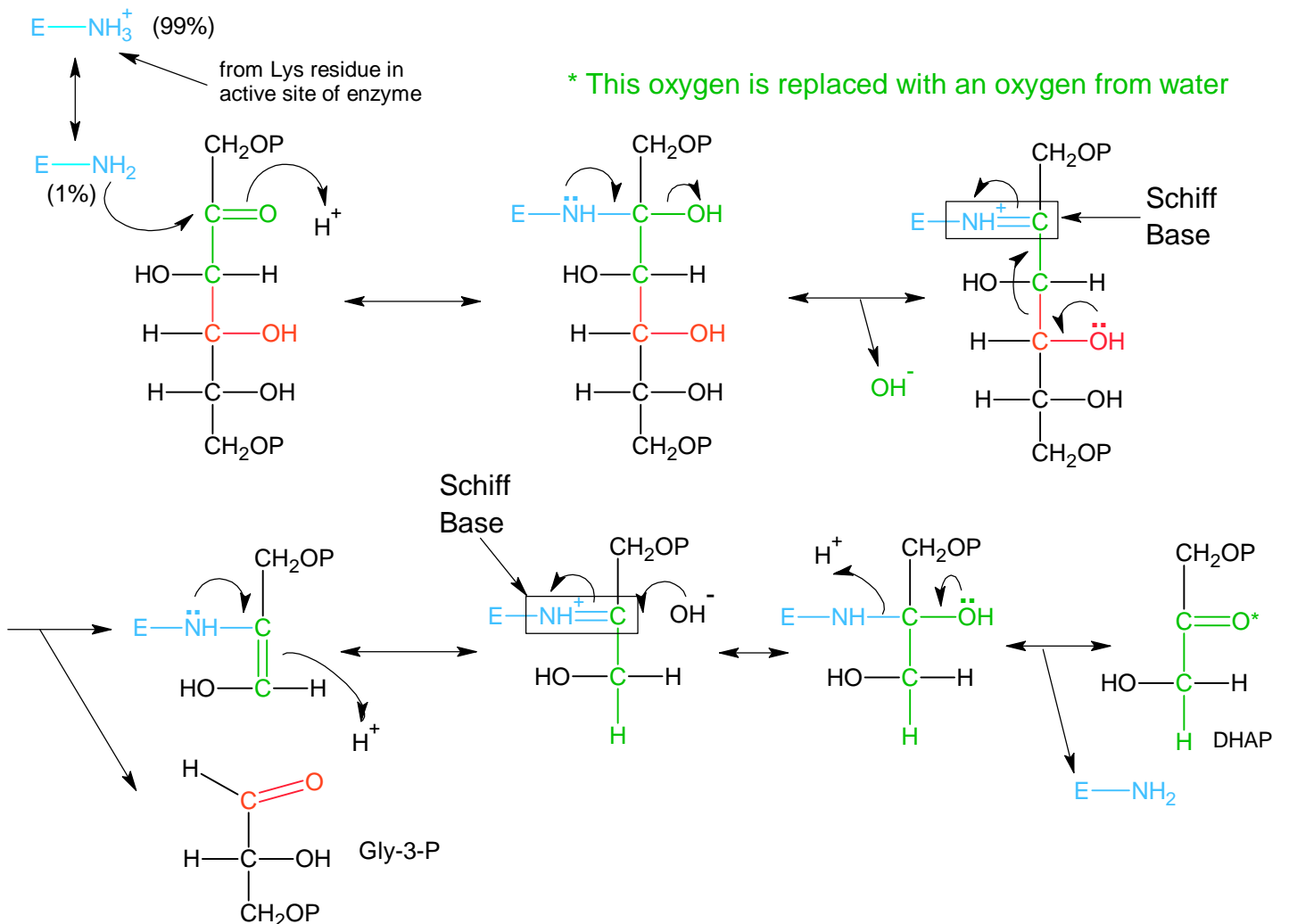

Based on a Handout Created by '01 TA Chris Allen